

Pentastar Press

Volume 34, Issue 11

November, 2015



www.dallasmoparclub.com
dallasmoparclub@group.facebook.com
dallasmoparclub@gmail.com

Officers

President – Tracy Barenz	469-343-9087
Vice-President – Clint Cash	972-742-8191
Secretary – Lee Elm	972-276-2934
Treasurer – Mike Boyd	972-762-4777

Directors at Large

Frank Maxwell (8/14 – 7/16)	214-577-5187
Bill Bonney (1/14 – 12/15)	214-769-5314
Bob Ostrowski (4/15 – 3/17)	469 286 7879

Membership Committee

Bill Bonney	214-769-5314
Brad Buttermore	214-202-7480

Event Coordination

Clint Cash	972-742-8191
Arthur Clarke, Staff / "DJ"	214-946-3867
Robert Vaughn, Cruise & Race	972-998-7381

Newsletter

Tracy Barenz	469-343-9087
--------------	--------------

Contact Information

Visit our sponsor for discounts:

Chrysler Jeep Dodge City of McKinney

700 S Central Expy McKinney, TX 75070
972-569-9650



CHRYSLER JEEP DODGE CITY OF MCKINNEY 700 S Central Expy - McKinney, TX 75070-3834
Sales: (877) 288-7471
www.dodgecityofmckinney.net

www.dodgecityofmckinney.net



"2015" DMC Hole Shot

Tracy Barenz, Dallas Mopar Club President

The state fair had a good turn out even with conflicting events that took fellow members away from the fair; we had 9 cars and excellent weather.

November is Nominations time for board members we have following positions that will be open for nominations.

President: Currently held by Tracy Barenz. (I will not be seeking reelection this year since I will be doing the newsletter).

Vice President: Currently held by Clint Cash

Treasurer: Currently held by Mike Boyd

Secretary: currently held by Lee Elms

Board Position #1: Currently held by Bill Bonney

The above positions are eligible for reelection.

Or if you have any recommendations for officers please nominate them.

Elections will be held at the Christmas party Dec 5 2015

Tracy Barenz, President

Dallas Mopar Club

469-343-9087

Barenzt@sbcglobal.net

Minutes from the DMC Club Meeting

Dallas Mopar Club September 13th 2015 Spring Creek Bar-B-Que

Dallas Mopar Club Meeting

October 11th, 2015

SpringCreek BarBQ

The meeting was called to order at 2:05pm by President Tracy Barenz.

Tracy went over some of the topics we covered at the Friday Board Meeting.

The Christmas Party will be on December 5th, and will be held at the Garland Senior Center from 6pm to 9pm. The room is ours from 5pm to 10pm so that gives us time to set up decorations and then afterward the clean-up. We are going to invite Dickeys' BarBQ to cater the dinner like they did last year. If anyone would like to provide some Christmas music for us to listen to that would be nice. We are having the Christmas gift exchange game again this year and if you want to play Bingo this year we can try that too. The gifts should be around \$20 or \$25 in value, and no "gag gifts" please.

Elections are coming up, the President, Vice President, Treasurer and Secretary. The people that are in that office right now can serve one more year in that capacity if you want them to. The elections will be held at the Christmas Party, also our board meeting and club meeting....very informal.

Since Ray has retired from his position as newsletter editor, Tracy is taking it on, and he is looking for articles for the newsletter, and especially stories about your Mopar. So please send all that information to Tracy.

The Car Corral at the State Fair will be next Saturday.

November 7th is the Whitewright Car Show and Fall Festival

November 14th is the Edgewood Car Show and Fall Festival

Our November 8th Board Meeting will be at Bob Ostrowskis' Art Studio at Valley View Mall at 11:30am. Afterwards we will come to SpringCreek BarBQ for our regular November 8th meeting at 2pm. Anyone is welcome to attend the board meetings. The studio is on the 2nd floor towards the back of the mall. The order at the board meetings will be held throughout the year will be President, Vice President, Board member #1, Board member #2, and Board member #3, then President, Vice President, Board member #1, Board member #2, Board member #3, then the Secretary and then the Treasurer.

We are going to look at the club by-laws and do away with having an "associates" membership. We will only have a Single and a Family membership.

We are also going to start working on the 2016 MiniNats in January. We need to be actively getting sponsors, and design the tee shirts and awards. We also want to come up with more club activities.

The first half of the 50/50 pot, \$7.50 was won by Steve Jones.

The favorite car for \$7.50 was won by Ron Rendelman

The meeting was adjourned at 3:05pm.

Respectfully submitted,

Lee Elms, Secretary



September membership update:

Membership Awards presented at 2015 MiniNats

Barnett Family 8 Years, awarded 5 year pins

Shelton Family 10 Years, awarded 10 year pins

Latest joins since last published in August:

Last Name	First Name	Year	Membership	Join Date
Whitfield	Christy	2015	Associate	26-Jul-15
Wolfe	Scott	2015	Individual	28-Jul-15
Rhoades	James	2015	Associate	19-Aug-15
Davis	Robinson	2015	Associate	20-Aug-15
Fry	Jerry	2015	Associate	20-Aug-15
Snider	David	2015	Individual	03-Sep-15
Bolton	Craig	2015	Associate	21-Oct-15

Feature Car / Truck:



The Car Corral at the State Fair of Texas



Dylan's 1967 Plymouth fury III



Terrys 1979 Chrysler 300



Alberts 2010 Dodge Ram



Brad's 1966 Charger



Kevins 1970 Charger



Tracy's 1967 Chrysler Newport Custom



Jerry's 1987 Dodge Ram



Don's 1966 Plymouth Belvedere 'wambulance'



JoAn's 2009 Dodge Charger

In Case You Missed It...



Up and Coming Mopar Events: Membership Dues are Pro-rated at Mid-Year. See application for details on our club web site: www.dallasmoparclub.com

MONTHLY CRUISE UPDATE

Looking forward to seeing you on the road: Brad.buttermore@cadallas.com 214-202-7480 Cell

GRAND STREET FALL FESTIVAL: TBD, WHITEWRIGHT, TX

CONTACT BRAD BUTTERMORE FOR CRUISE DETAILS.

HERITAGE FESTIVAL AND CAR SHOW: NOVEMBER 7, EDGEWOOD, TX

CONTACT BRAD BUTTERMORE FOR CRUISE DETAILS.

CHRISTMAS PARTY: DECEMBER 5, GARLAND SENIOR ACTIVITY CENTER CONTACT LEE ELMS FOR DETAILS.

BOARD MEETING : NOVEMBER 8, HOSTED BY BOB OSTROWSKI AT HIS ART STUDIO IN THE VALLEY VIEW MALL @ 11:30 CONTACT BOB OSTROWSKI 469 286 7879

Board meeting is a go at my studio at Valley View Mall. The mall should be open by 10:00 on Sunday. To find my space, enter the mall like your going to the movie theater on the Preston side, just north of Sears. Go to the center of the mall and find the arm with the store "Sky Pony" on one side and "The Midtown Gallery" on the other side. There is also a full size horse covered with beads and sequins stationed there. Go to the very end and find "Midtown Artist Studios on the right. That be the place.

Tech Article



A 1970 Challenger Rally Cluster Ammeter to Voltage Conversion:

By Bill Bonney
Part 2 of 3

My winter project continues with the addition of power windows and wiring upgrades. The first installment covered the replacement of the failure prone ammeter with a voltmeter. That process has gone well and really exceeded my expectations in look and function.

The next part was the conversion of the alternator wiring using a modification found in several Mopar magazines and the MAD wiring diagram shown in figure 1. All owners of classic Mopars from the 60's and 70's know that the alternator lead (BK) ran through the firewall bulkhead connector with a push together connection to the in dash ammeter and then a (RED) lead out to the starter relay using another push together connection through the firewall bulkhead connector. This "push together connector" created the least reliable connection for a heavy load circuit and resulted in a failure point at the block connector as the heat generated caused the block to melt where the charge lead went through. It is a wiring method that often caused an electrical failure with a possible fire and reduced the driver to "pedestrian status."

According to the wiring diagram for my Challenger the alternator leads to and from the ammeter is 12 gauge. With the additional drain of the power windows, power convertible top, power door locks, power mirrors and air conditioning, I planned to add a 78A alternator from a 1980 Dodge Diplomat and the existing 12 gauge is only good for 25-45 amps. Therefore, a new 10 gauge (BK) lead was run from the alternator to the starter relay and terminated using a 14 gauge fusible link. The existing 12 gauge alternator lead was hidden in the wiring bundle at both the alternator and firewall ends so no OEM wiring was cut except to remove the push on connectors at the bulkhead connector.

The existing two leads which had terminated on the ammeter, along with a power top lead and the lead to the power window circuit breaker were joined together using the OEM ring connectors on a Blue Sea 2010 Power Post Mini #10 conveniently mounted on the studs of the voltmeter. No wiring in the dash was cut except at the firewall block where the new leads were attached.

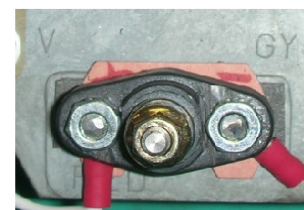

Rear view of the voltmeter with
Blue Sea 2010 Power Post Mini #10
mounted on rear



Bus Bars with leads attached



Interior view of bulkhead connector

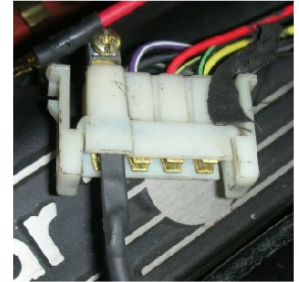

Bulkhead connector with bus bar in place

Bus bars were added through the firewall connector block by purchasing two (2) AC electrical wall plugs and soldered the plug stems together so I could utilize screw connectors on both ends. With the help of Brad Buttermore, who was in my shop for the day, and

with some brute force fit, we were able to fish the lead through the connector and then through the firewall block. That was tough as the hole in the connector was just large enough to accept the bus bars, and still be snug, due to the heat shrink that I had added. The new leads were then connected to the existing leads under the dash at the firewall. The RED lead which ran from the ammeter to the starter relay was reconnected at the bulkhead connector. A new 12 gauge BLACK lead was connected at the firewall bulkhead connector and terminated on the starter relay with a 16 gauge fusible link.

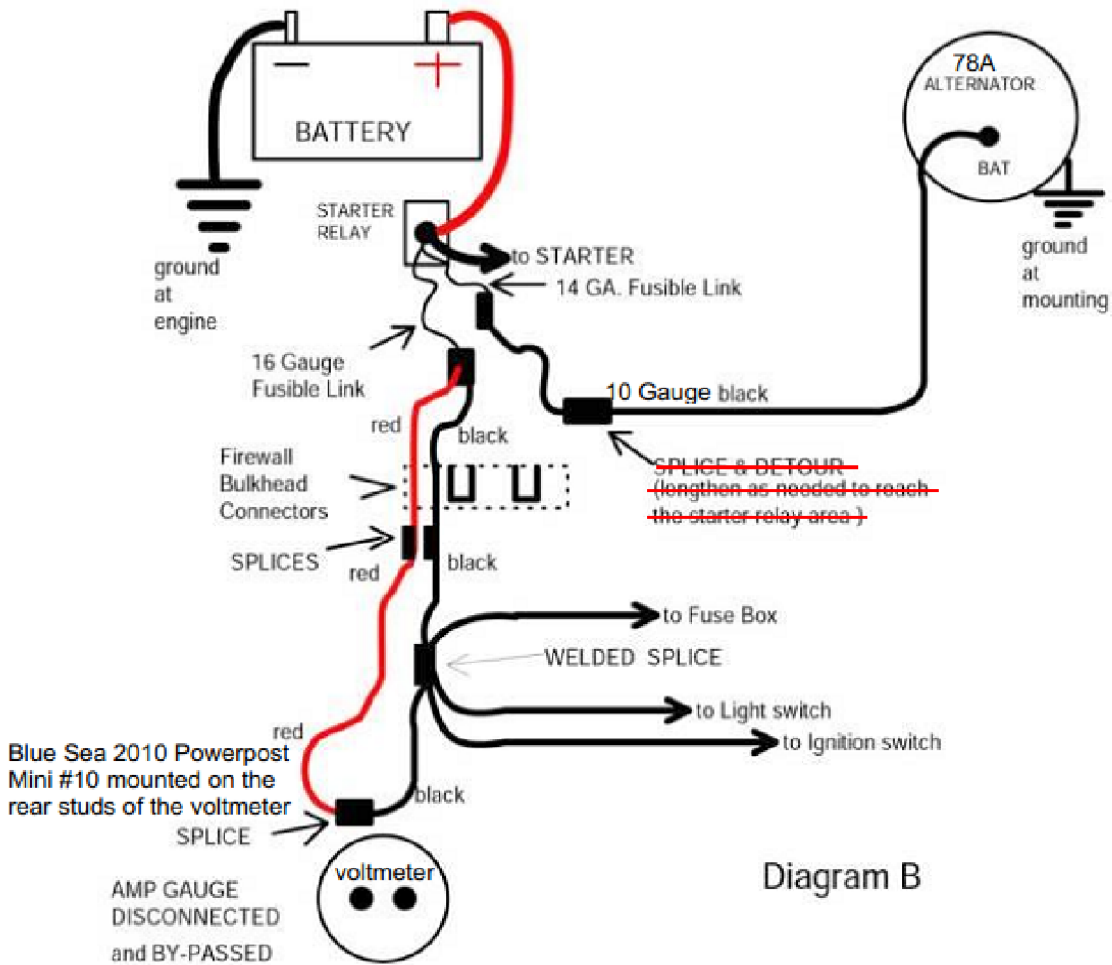

Diagram B

Figure 1: M.A.D. Engineering wiring diagram

Mopar's: For Sale - Cars Wanted – Stuff

Club Member and Sponsor Clint Cash wants to let you know "WE BUY HOUSES!" WE STOP FORECLOSURE!
WE MAKE OFFERS! (972)742-8191

- Need a **Quick Sale?** Don't Repair it, Sell it! We can buy it!
- We Can **Stop/ Cancel Foreclosure!**
- We **take over payments!** We **catch up payments.**
- Have **NEGATIVE or ZERO EQUITY?** **Can't sell your house?** WE BUY THEM!
- Have Equity, **we pay CASH!**
- We can close as soon as 24 hours! Most closings are within days!
- Is the bank telling you to do a **SHORT SALE?** We can get an offer submitted immediately! Although, there are still other options to pay your house in full.
- Loan modification denied? **CALL US! WE CAN HELP!!**
- Property in Probate or Inherit a property? We can make you an offer!
- **There is no charge for our Services.**



I BUY HOUSES!
I MAKE OFFERS!

Clint Cash
Real Estate Investor
(972) 742-8191 phone
(972) 395-1434 fax
clint.cash@gmail.com

Serving Collin, Dallas,
Denton, and Tarrant
Counties in Texas.

Don't lose your house to foreclosure. Let me help you save your credit.

Dallas Mopar Club, Inc.

PentaStar Press is the official publication of the Dallas Mopar Club, Inc., which is solely responsible for its contents. Any views or opinions expressed by the authors might not express the views of the Dallas Mopar Club, Inc. Other non-profit classic automobile clubs, provided proper credit is given to its source, may reprint all material in the PentaStar Press, including artwork. We ask that two copies of reprints be sent to the editor of this newsletter; one for the author, the other for the club archives. Commercial publications wishing to reprint an entire article should contact the editor for permission.

Send all contributions for this newsletter to:

Dallas Mopar Club, Inc.
PO Box 472601
Garland, Texas 75047
Or email to Tracy Barenz barenzt@sbcglobal.net

Thanks to all our Sponsors of the Wylie Bluegrass on Ballard Classic Car Show



HAMBURGERS
Voted Best in Wylie
972-442-3825

96° West

96 degree West Winery
David Hunt
972-358-9818
www.96westwinery.com
david@96westwinery.com



Garage
Kirk VanMeter
972-670-2332



972-442-7508
www.barnhartrealtygroup.com



1-888-6GRUNDY



JC Worley
972-442-6293
www.jcironworks.com
jcw@jcironworks.com

J & B Body Shop
Advanced Collision
Specialist

Jack Scheel
972-442-4372



972-840-8412
www.rodscarcraft.com



972-461-0776
www.richs-performance-mufflers.com



State Farm Agent
Adam Leggett
972-941-9400
adam@adamleggett.net

The
Law Office of
Deborah Matern
972-442-5700
www.wylieattorney.com



NEW AND USED TIRES
LAVON, TX



with you through LIFE
Kevin Finnell, FICE
214-914-6770

Wylie
Eye
Center
972-429-9090

RICK'S HOME STORE

Rustic Furniture & Accessories
Rick DeFoe
972-575-8855

DICKEYS
BARBECUE PIT

★★★ WYLIE, TX ★★★
972-429-8525
www.Dickeys.com

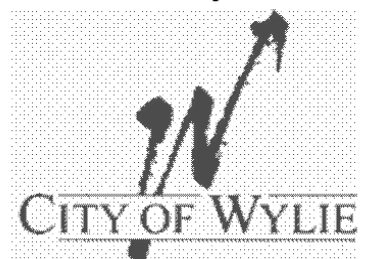

Meeting Information:

Monthly meeting 2nd Sunday of each month at 2:00 pm, Spring Creek BBQ,
12835 Preston Rd. SW Corner of Preston and LBJ

BOARD MEETING INFORMATION

(Based on current officer and board positions)

<i>January – Tracy Barenz, President</i>	<i>July – Clint Cash, Vice President</i>
<i>February – Clint Cash, Vice President</i>	<i>August – Director 1, Bill Bonney</i>
<i>March – Director 1, Bill Bonney</i>	<i>September – Director 2, Frank Maxwell</i>
<i>April – Director 2 Frank Maxwell</i>	<i>October – Director 3, Bob Ostrowski</i>
<i>May – Director 3, Bob Ostrowski</i>	<i>November – Lee Elm, Secretary</i>
<i>June – Tracy Barenz, President</i>	<i>December – Mike Boyd, Treasurer</i>

Board meetings are open to all club members: Board meetings are usually held at an Officer's or Director's home starting at 7:30PM the Friday before the Sunday monthly Club meeting and all members are encouraged to attend. Check the DMC website for any last minute time or location changes.

Our Sincere thanks go to Jim Proctor and the staff of Chrysler Jeep Dodge City of McKinney their support of the Dallas MOPAR Club



700 S. Central Expy McKinney, TX 75070
Sales: (877) 627-1395 Parts & Service: (972) 569-9650

Need Speed?

Chrysler Jeep Dodge City of McKinney can help you with all of your performance needs.

We work on all Makes and Models.

Sales, Parts & Service Department: Employee Pricing Discount bring us a copy of this page of the newsletter for proof you are a member of the Dallas MOPAR Club.